

Homogenizer HST - HLE37

- Standard capacity 22 gal/min
- Standard homogenizer pressure 2,901 PSI
- Absorbed motor power: 50 hp
- Aseptic execution is optional
- Sustainable for processing high viscosity products
- Unique design in accordance with the conditions of use simple installation, economic design, and easy maintenance

Weight with motor: Approx. 3,968 lbs
 Technical changes reserved!

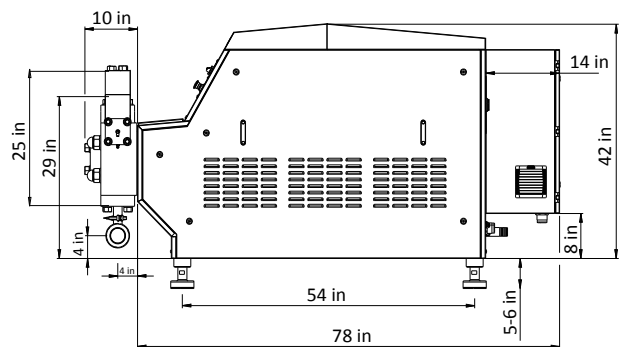
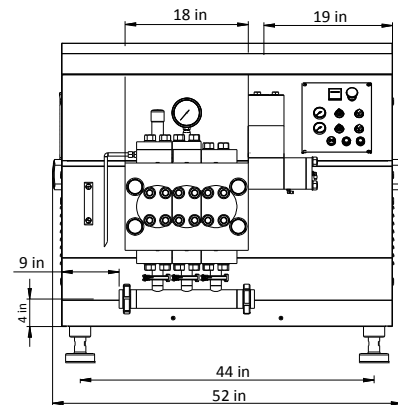

| Model | Max. Capacity | Max. Pressure |
|------------|---------------|---------------|
| HST-HLE37 | GPM | PSI |
| HLE37-130 | 31 | 1,885 |
| HLE37-170 | 26 | 2,466 |
| HLE37-200 | 22 | 2,901 |
| HLE37-250 | 18 | 3,626 |
| HLE37-300 | 13 | 4,351 |
| HLE37-400 | 11 | 5,802 |
| HLE37-500 | 7 | 7,252 |
| HLE37-750 | 4 | 10,878 |
| HLE37-1000 | 3 | 14,504 |

| Model | Max. Speed | Max. Diameter |
|------------|-------------|---------------|
| HST-HLE37 | RPM (Speed) | MM (Diameter) |
| HLE37-130 | 123 | 70 |
| HLE37-170 | 145 | 60 |
| HLE37-200 | 123 | 60 |
| HLE37-250 | 116 | 55 |
| HLE37-300 | 123 | 50 |
| HLE37-400 | 129 | 45 |
| HLE37-500 | 123 | 35 |
| HLE37-750 | 123 | 30 |
| HLE37-1000 | 123 | 20 |