

Homogenizer HST - HLE45

- Standard capacity 26 gal/min
- Standard homogenizer pressure 2,901 PSI
- Absorbed motor power: 60 hp
- Aseptic execution is optional
- Sustainable for processing high viscosity products
- Unique design in accordance with the conditions is use simple installation, economic design, and easy maintenance

Weight with motor: Approx. 3,968 lbs
 Technical changes reserved!

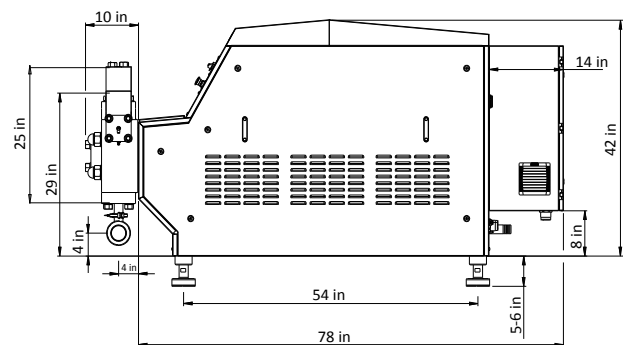
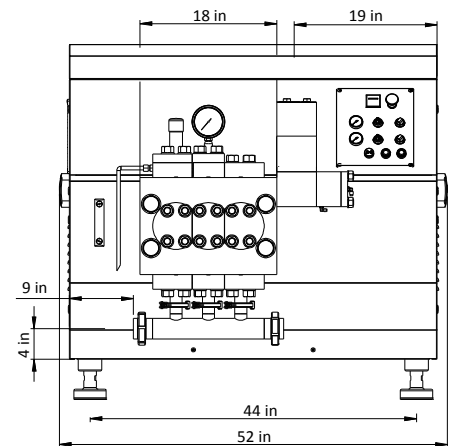

Model	Max. Capacity	Max. Pressure
HST-HLE45	GPM	PSI
HLE45-130	32	1,885
HLE45-170	29	2,466
HLE45-200	26	2,901
HLE45-250	22	3,626
HLE45-300	15	4,351
HLE45-400	12	5,802
HLE45-500	8	7,252
HLE45-750	6	10,878
HLE45-1000	4	14,504

Model	Max. Speed	Max. Diameter
HST-HLE45	RPM (Speed)	MM (Diameter)
HLE45-130	123	70
HLE45-170	145	60
HLE45-200	123	60
HLE45-250	116	55
HLE45-300	123	50
HLE45-400	129	45
HLE45-500	123	35
HLE45-750	123	30
HLE45-1000	123	20