

# Homogenizer HST - HLE7.5

- Standard capacity 4 gal/min
- Standard homogenizer pressure 2,901 PSI
- Absorbed motor power: 10 hp
- Aseptic execution is optional
- Sustainable for processing high viscosity products
- Unique design in accordance with the conditions is use simple installation, economic design, and easy maintenance



Weight with motor: Approx. 992 lbs

Technical changes reserved!

Model	Max. Capacity (GPM)	Max. Pressure (PSI)
HST-HLE7.5	GPM	PSI
HLE7.5-170	5	2,466
HLE7.5-200	4	2,901
HLE7.5-400	2	5,802
HLE7.5-700	1	10,153
HLE7.5-1000	.5	14,504

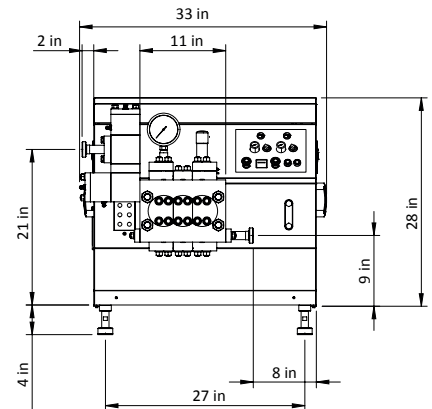

Model	Max. Speed	Max. Diameter
HST-HLE7.5	RPM (Speed)	MM (Diameter)
HLE7.5-170	160	30
HLE7.5-200	118	25
HLE7.5-400	110	20
HLE7.5-700	110	16
HLE7.5-1000	110	12

